

**CORCORAN CITY COUNCIL,
JOINT POWERS FINANCE AUTHORITY,
SUCCESSOR AGENCY FOR CORCORAN RDA,
& HOUSING AUTHORITY
AGENDA**

**City Council Chambers
1015 Chittenden Avenue
Corcoran, CA 93212**

**Tuesday, February 8, 2022
5:30 P.M**

Public Inspection: A detailed City Council packet is available for review at the City Clerk's Office, located at Corcoran City Hall, 832 Whitley Avenue.

Notice of ADA Compliance: In compliance with the Americans with Disabilities Act, if you need assistance to participate in this meeting, please contact the City Clerk's Office at (559) 992-2151.

ROLL CALL

Mayor:	Patricia Nolen
Vice Mayor:	Jeanette Zamora-Bragg
Council Member:	Greg Ojeda
Council Member:	Sidonio "Sid" Palmerin
Council Member:	Jerry Robertson

INVOCATION

FLAG SALUTE

1. PUBLIC DISCUSSION

Members of the audience may address the Council on non-agenda items; however, in accordance with government code section 54954.2, the Council may not (except in very specific instances) take action on an item not appearing on the posted agenda.

This is the time for members of the public to comment on any matter within the jurisdiction of the Corcoran City Council. This is also the public's opportunity to request that a Consent Calendar item be removed from that section and made a regular agenda item. The councilmembers ask that you keep your comments brief and positive. Creative criticism, presented with appropriate courtesy, is welcome.

After receiving recognition from the chair, speakers shall state their name and address and proceed with comments. Each speaker will be limited to five (5) minutes.

2. **CONSENT CALENDAR (VV)**

All items listed under the consent calendar are considered to be routine and will be enacted by one motion. If anyone desires discussion of any item on the consent calendar, the item can be removed at the request of any member of the City Council and made a part of the regular agenda.

- 2-A. Approval of minutes of the meeting of the City Council on January 25, 2022.
- 2-B. Authorization to read ordinances and resolutions by title only.
- 2-C. Ratify Proclamation No. 2022-01 through 2022-03 honoring Chamber of Commerce Honorees
- 2-D. Consider Rejection of the Claim by Gallardo Family.
- 2-E. Consider Rejection of the Claim by Dee Allen Brannum Jr.

3. **APPROPRIATIONS (VV)**

Approval of Warrant Register dated February 8, 2022. *(Ruiz-Nuñez) (VV)*

4. **PRESENTATIONS** – None

5. **PUBLIC HEARINGS** – None

6. **WRITTEN COMMUNICATIONS** – None

7. **STAFF REPORTS**

- 7-A. Letter of Support for Tulare Lake Subbasin Groundwater Projects. *(Gatzka) (VV)*
- 7-B. Consider approving Resolution No. 3117 to authorize the City Manager to apply for CalRecycle grants for the next 5 years. *(Gatzka) (VV)*

8. **MATTERS FOR MAYOR AND COUNCIL**

- 8-A. Information Items
- 8-B. Staff Referral Items - *Items of Interest (Non-action items the Council may wish to discuss)*
- 8-C. Committee Reports

9. **CLOSED SESSION** – None

10. **ADJOURNMENT**

I certify that I caused this Agenda of the Corcoran City Council meeting to be posted at the City Council Chambers, 1015 Chittenden Avenue on February 3, 2022.

Marlene Spahr, City Clerk

**MINUTES
CORCORAN CITY COUNCIL,
JOINT POWERS FINANCE AUTHORITY,
SUCCESSOR AGENCY FOR CORCORAN RDA,
& HOUSING AUTHORITY REGULAR MEETING**

Tuesday, January 25, 2021

The regular session of the Corcoran City Council was called to order by Mayor Nolen, in the City Council Chambers, 1015 Chittenden Avenue, Corcoran, CA at 5:32 P.M.

ROLL CALL

Councilmembers present: Patricia Nolen, Greg Ojeda, Sidonio Palmerin, Jerry Robertson and Jeanette Zamora-Bragg

Councilmembers absent:

Staff present: Greg Gatzka, Soledad Ruiz-Nuñez, Reuben Shortnacy, Marlene Spain and Kevin Tromborg

Press present: None

INVOCATION - Invocation was led by Councilmember Palmerin

FLAG SALUTE – Flag salute was led by Councilmember Ojeda

1. **PUBLIC DISCUSSION** – None

2. **CONSENT CALENDAR (VV)**

Following Council discussion, a **motion** was made by Robertson and seconded by Ojeda to approve the Consent Calendar. Motion carried by the following vote:

AYES: Nolen, Ojeda, Palmerin, Robertson and Zamora-Bragg

NOES:

ABSENT:

ABSTAIN: Zamora-Bragg abstained from the Minutes.

2-A. Approval of minutes of the meeting of the City Council on January 11, 2021.

2-B. Authorization to read ordinances and resolutions by title only.

2-C. Move to accept the Notice of Completion for the 2020 Road Maintenance Project.

3. **APPROPRIATIONS (VV)**

Following Council discussion, a **motion** was made by Zamora-Bragg and seconded by Ojeda to approve warrant register dated January 25, 2022. Motion carried by the following vote:

AYES: Nolen, Ojeda, Palmerin, Robertson and Zamora-Bragg
NOES:
ABSENT:

4. PRESENTATIONS

4-A. A presentation was given by Kendall Flint regarding the Kings County Regional Transportation Plan (RTP).

5. PUBLIC HEARINGS – None

6. WRITTEN COMMUNICATIONS – None

7. STAFF REPORTS

7-A. Following Council discussion, a **motion** was made by Robertson and seconded by Ojeda to accept the of Final Subdivision Map 21-02 and Resolution 3116 regarding TSDM 880 approved by the Corcoran Planning Commission on July 10, 2006. Motion carried by the following vote:

AYES: Nolen, Ojeda, Palmerin, Robertson and Zamora-Bragg
NOES:
ABSENT:

7-B. Following Council discussion, a **motion** was made by Robertson and seconded by Ojeda to award the remaining years of 2021-2024 Vehicle Abatement Contract to Art Towing Service. Motion carried by the following vote:

AYES: Nolen, Ojeda, Palmerin, Robertson and Zamora-Bragg
NOES:
ABSENT:

7-C. Finance Director, Soledad Ruiz-Nuñez presented the revenues and expenses for the period beginning July 1, 2021 through December 31, 2021 for review.

7-D. Maricela Lerma of the Lerma Ad Hoc Committee gave an update to Council.

7-E. Following Council discussion, a **motion** was made Robertson and seconded by Zamora-Bragg to appoint Tina Botill to the Kings County Mosquito Abatement District Board as a representative of Corcoran. Motion carried by the following vote:

AYES: Nolen, Ojeda, Palmerin, Robertson and Zamora-Bragg
NOES:
ABSENT:

8. MATTERS FOR MAYOR AND COUNCIL

- 8-A.** Council received information items.
- 8-B.** Staff received referral items.
- 8-C.** Committee reports.

CLOSED SESSION – None

ADJOURNMENT **7:27 P.M.**

Patricia Nolen, Mayor

Marlene Spain, City Clerk

APPROVED DATE: _____

City of

CORCORAN

A MUNICIPAL CORPORATION

FOUNDED 1914

CONSENT CALENDAR ITEM #: 2-C

MEMO

TO: Corcoran City Council

FROM: Marlene Spain, Assistant to the City Manager/City Clerk

DATE: February 3, 2022 **MEETING DATE:** February 8, 2022

SUBJECT: Ratify Proclamation No. 2022-01 through 2022-03 honoring Chamber of Commerce Honorees

Recommendation: (Consensus)

As part of the consent calendar acknowledge ratify Proclamation No. 2022-01 through 2022-03.

Discussion:

Annually the Chamber of Commerce recognizes citizens and organizations, as Man of the Year, Woman of the Year, Junior Citizen of the Year, and Organization of the Year. The City Council approves the Proclamations acknowledging the accomplishments of those honored and presents them at the Chamber's Annual dinner.

Budget Impact:

None

Attachments:

Proclamation 2022-01, Man of the Year
Proclamation 2022-02, Woman of the Year
Proclamation 2022-03, Jr. Citizen of the Year

City Offices

PROCLAMATION 2022 - 01
of the City Council of the City of Corcoran
HONORING

Isaias Ramirez

- WHEREAS,** the Corcoran Chamber of Commerce hosts an annual event to recognize and honor individuals who are exemplary in their service to the community; and,
- WHEREAS,** the Chamber of Commerce has selected Isaias Ramirez as “Man of the Year” for his contribution of time and commitment to the community of Corcoran; and,
- WHEREAS,** Mr. Ramirez is currently the Corcoran Chamber of Commerce Board of Directors, Cross Country and Track Coach, part of the Corcoran High School Football program, Positive Behavior Interventions and Supports (PBIS) Team and Environmental, Protection, Involvement Club (EPIC); and,
- WHEREAS,** Mr. Ramirez along with his athletes volunteer to help for Corcoran events such as the Farmers’ Market, Christmas celebrations, and Rotary functions and Cotton Festival; and,
- WHEREAS,** Mr. Ramirez one of the most caring and selfless teachers on campus, and is considered a “Life Coach” to his students.

NOW, THEREFORE, BE IT RESOLVED that the City Council of the City of Corcoran hereby congratulates

Isaias Ramirez

on being selected as the Corcoran Chamber of Commerce MAN OF THE YEAR and adds its thanks for the contributions he has made to the betterment of this community.

PASSED AND ADOPTED at a regular meeting of the Corcoran City Council held on the 2th day of February 2022.

Patricia Nolen, Mayor

Jeannette Zamora-Bragg, Vice-Mayor

Sidonio “Sid” Palmerin, Council Member

Jerry Robertson, Council Member

Greg Ojeda, Council Member

PROCLAMATION 2022-03

**of the City Council of the City of Corcoran
HONORING**

Amanda Curtis

WHEREAS, the Corcoran Chamber of Commerce hosts an annual event to recognize and honor individuals who are exemplary in their service to the community; and,

WHEREAS, the Chamber of Commerce has selected Amanda Curtis as “Jr. Citizen of the Year” and,

WHEREAS, Amanda Curtis is currently on the Corcoran 4-H, including Emerald Star Project, County Ambassador and All-Star, Vice President, Teen Leader; Church of Jesus Christ of Latter-Day Saints Young Women's Organization, holding office of Class President; Corcoran High School Yearbook-Editor; Big Brothers/Big Sisters-Big Sister, 100th Corcoran Christmas Tree Committee Queen; and,

WHEREAS, Amanda volunteers at the Cotton Festival, Farmers' Market, Christmas Tree Committee and Corcoran Rotary; and,

WHEREAS, Amanda did an Emerald Star Project in which she made and collected over 500 pillowcases for foster kids in Corcoran and throughout Kings County. She has used her experience as a foster youth as inspiration to help other youth in Corcoran and beyond.

NOW, THEREFORE, BE IT RESOLVED the Mayor and City Council of the City of Corcoran hereby congratulates

Amanda Curtis

on being selected as the Corcoran Chamber of Commerce JR. CITIZEN OF THE YEAR and adds its thanks for the contributions she has made to the betterment of this community.

PASSED AND ADOPTED at a regular meeting of the Corcoran City Council held on the 2th day of February 2022.

Patricia Nolen, Mayor

Jeannette Zamora-Bragg, Vice-Mayor

Sidonio “Sid” Palmerin, Council Member

Jerry Robertson, Council Member

Greg Ojeda, Council Member

PROCLAMATION 2022 - 02
of the City Council of the City of Corcoran
HONORING

Katlyn Smith

WHEREAS, the Corcoran Chamber of Commerce hosts an annual event to recognize and honor individuals who are exemplary in their service to the community; and,

WHEREAS, the Chamber of Commerce has selected Katlyn Smith as “Woman of the Year” and,

WHEREAS, the recognition is an opportunity to acknowledge the contributions and talents of a local resident who dedicates their time and talents to the community of Corcoran; and,

WHEREAS, Katlyn Smith is a Corcoran Chamber Member, RAC Board Member, Corcoran Little League President, Corcoran Blue Dolphins President, School Site Councils Muir President, Corcoran Christmas Tree Committee, Alternate on the Corcoran Planning Commission; and,

WHEREAS, Katlyn Smith always goes the extra mile to create better programs in Corcoran which benefit not only the youth, but everyone in the community.

NOW, THEREFORE, BE IT RESOLVED that the City Council of the City of Corcoran hereby congratulates

Katlyn Smith

on being selected as the Corcoran Chamber of Commerce WOMAN OF THE YEAR and adds its thanks for the contributions she has made to the betterment of this community.

PASSED AND ADOPTED at a regular meeting of the Corcoran City Council held on the 2th day of February 2022.

Patricia Nolen, Mayor

Jeannette Zamora-Bragg, Vice-Mayor

Sidonio “Sid” Palmerin, Council Member

Jerry Robertson, Council Member

Greg Ojeda, Council Member

City of

CORCORAN

FOUNDED 1914

A MUNICIPAL CORPORATION

CONSENT CALENDAR ITEM #: 2-D

MEMO

TO: Corcoran City Council

FROM: Marlene Spain, City Clerk

DATE: February 1, 2022 **MEETING DATE:** February 8, 2022

SUBJECT: Consider Rejection of the Claim by Gallardo Family.

Recommendation:

Move to approve the Consent Calendar and reject the claim by the Gallardo Family.

Discussion:

On January 6, 2022, staff received a claim application from Banafshe Law Firm on behalf of the Gallardo Family. According the claim application, the claimant(s) alleges the City of Corcoran did not take safety measures to prevent anyone from falling into canals and waterways at 6th and Pueblo Ave . The claim was forwarded to the City's third party administrator, Acclamation Insurance Management Services (AIMS), as part of the City's participation in the Central San Joaquin Valley Risk Management Authority (CSJVRMA).

AIMS recommends the City consider issuing a notice of rejection for the claim.

A copy of the claim will be provided upon request.

Budget Impact:

This type of claim is handled through the City's Risk Management Authority (RMA).

City Offices

City of

CORCORAN

A MUNICIPAL CORPORATION

FOUNDED 1914

CONSENT CALENDAR ITEM #: 2-E

MEMO

TO: Corcoran City Council

FROM: Marlene Spain, City Clerk

DATE: February 5, 2021 **MEETING DATE:** February 9, 2021

SUBJECT: Consider Rejection of the Claim by Dee Allen Brannum Jr.

Recommendation:

Move to approve the Consent Calendar and reject the claim by Dee Allen Brannum Jr.

Discussion:

On December 22, 2022, staff received a claim application from Downtown LA Law on behalf of Dee Allen Brannum Jr. According to the claim application, the claimant alleges the City of Corcoran's Public Works Department failed to properly maintain the roadway and has failed to warn then general public of dangerous conditions at Ave. 120 and 4th Ave. The claim was forwarded to the City's third party administrator, Acclamation Insurance Management Services (AIMS), as part of the City's participation in the Central San Joaquin Valley Risk Management Authority (CSJVRMA).

AIMS recommends the City consider issuing a notice of rejection for the claim.

A copy of the claim will be provided upon request.

Budget Impact:

This type of claim is handled through the City's Risk Management Authority (RMA).

City Offices

**STAFF REPORT
ITEM #: 7-A****MEMO****TO: Corcoran City Council****FROM: Greg Gatzka, City Manager****DATE: February 3, 2022****MEETING DATE: February 8, 2022****SUBJECT: Letter of Support for Tulare Lake Subbasin Groundwater Projects****Summary:**

Corcoran Irrigation District has requested a letter of support from the City of Corcoran for local Tulare Lake Subbasin Groundwater Recharge and Sustainability Projects.

Recommendation:

Consider retroactively authorizing the City Manager to send a letter of support for local groundwater enhancement projects.

Budget impact:

None with this action.

Background:

On January 24, 2022, the Corcoran Irrigation District (CID) sent a letter requesting a letter of support for local groundwater sustainability projects within the Tulare Lake Subbasin. CID is seeking grant funding for two projects. The first project proposes to deepen an existing basin located south of Nevada Avenue and east of 5th Avenue to increase storage and recharge capacity. The second project is the replacement of existing open canals with enclosed pipelines located northeast of Nevada Ave and State Highway 43 to enhance water delivery efficiency.

The deadline for letters of support was January 28, 2022, and did not allow for enough time to bring before the City Council. The City Manager prepared and submitted the attached letter on behalf of the city as these projects are considered to enhance local groundwater management efforts and use of State funding for construction. The City Manager is requesting the City Council retroactively authorize submittal of the attached letter of support.

Attachments:

City Manager Letter of Support.

Corcoran Irrigation District Letter

City of

CORCORAN

A MUNICIPAL CORPORATION

FOUNDED 1914

January 28, 2022

Gene Kilgore, General Manager
Corcoran Irrigation District
P.O. Box 566
Corcoran, CA 93212

Re: Letter of Support for Tulare Lake Subbasin Groundwater Recharge and
Sustainability Projects

Dear Mr. Kilgore:

The City of Corcoran supports the efforts of our representative El Rico GSA and the combined Tulare Lake Subbasin GSAs in their grant application with the California Department of Water Resources (DWR) for funding to support the Tulare Lake Subbasin Groundwater Recharge and Sustainability Projects. Two projects locally proposed by Corcoran Irrigation District (CID) will directly enhance our local groundwater recharge capacity and water distribution efficiency. The proposed deepening of the CID basin located south of Nevada Avenue and east of 5th Avenue will enhance local groundwater recharge capacity and allow for additional capture of excess flood water in wet years. The proposed CID replacement of existing open canals with enclosed pipelines located northeast of Nevada Avenue and State Highway 43 will also enhance water delivery efficiency and reduce evaporative loss. Projects like these are essential local investments if we are to enhance our groundwater resources.

The City of Corcoran fully supports these sustainable groundwater infrastructure investment projects. We also recognize our local communities need for grant funding to make improvement projects like these a reality. The City of Corcoran strongly encourages DWR to consider funding these sustainable groundwater projects.

Sincerely,



Greg Gatzka
City Manager

City Offices:

832 Whitley Avenue * Corcoran, CA 93212 * Phone 559.992.2151 * www.cityofcororan.com

DIRECTORS

PETER A. RIETKERK, PRESIDENT
MICHAEL A. BOYETT
BEAU HOWARD
MATHEW O. GILKEY
ERIK HANSEN

GENE KILGORE
MANAGER-TREASURER

TAMMY STEPHENS
OFFICE ADMINISTRATOR
ASSESSOR AND TAX COLLECTOR

MISTY VASQUEZ
HUMAN RESOURCES

Corcoran Irrigation District

P.O. BOX 566 - CORCORAN, CALIFORNIA 93212
TELEPHONE (559) 992-5165 - FAX (559) 762-7227

January 24, 2022

City of Corcoran
Greg Gatzka, City Manager
832 Whitley Avenue
Corcoran, CA 93212

Subject: Support for Tulare Lake Subbasin Groundwater Recharge and Sustainability Projects

Mr. Gatzka,

Corcoran Irrigation District and the El Rico GSA is seeking the support of the City of Corcoran (City) for the **Tulare Lake Subbasin Groundwater Recharge and Sustainability Projects** grants application being submitted by the Tulare Lake Subbasin GSAs to the California Department of Water Resources (DWR).

The projects and components proposed on the application offer opportunities to reduce reliance on groundwater through expanding surface water distribution systems and construction of groundwater recharge basins to capture flood flows to offset groundwater pumping and stabilize groundwater levels near Disadvantage Communities within the critically over-drafted subbasin. By stabilizing groundwater levels, the City's water quality may be benefited.

The efforts of the Tulare Lake Subbasin GSA's will provide immense benefits to our subbasin and the communities within. The City's support would be greatly appreciated.

Respectfully,

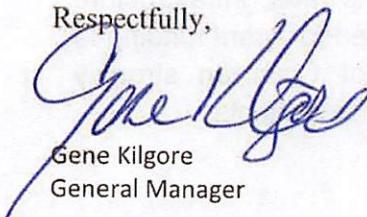

Gene Kilgore
General Manager

MEMBER, ASSOCIATION OF CALIFORNIA WATER AGENCIES



Know what's below.
Call before you dig.



PROJECT INDEX				
NAME	STATION START	STATION END	LENGTH	
SEGMENT 1	100+00	218+16	11,816 FT	2.2 MI
TURNOUT	100+00			
FLOW MEASURING STATION	103+00			
SEGMENT 2	218+16	315+71	9,755 FT	1.8 MI
PROPOSED TURNOUT	308+00			
CROSSING CAPACITY EXPANSION	315+71			
SEGMENT 3	315+71	358+03	4,232 FT	0.8 MI

NOTES

- STATIONING IS APPROXIMATE AT THIS STAGE PRIOR TO SURVEY

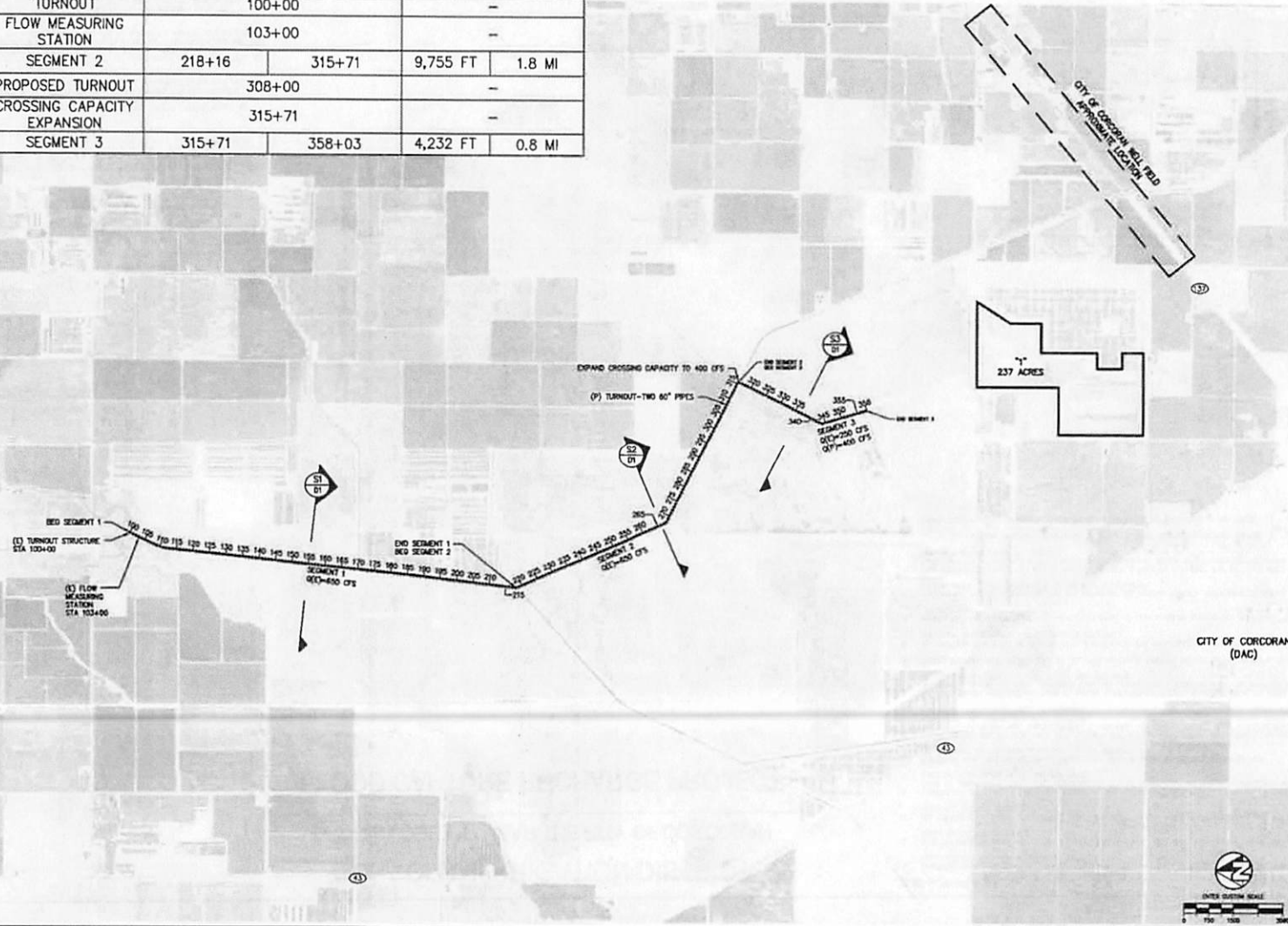

PROVOST & PRITCHARD
 REGIONAL ENGINEER
 C. WENZEL
 LICENSE NO. 58403
 SEAL

PROVOST & PRITCHARD
 REGIONAL ENGINEER
 C. WENZEL
 LICENSE NO. 58403
 SEAL

DESIGNED BY: AB
 CHECKED BY: CM
 DATE: 12/21/2022
 JOB NO: 20001
 PROJECT NO: 18-00000
 PHASE: P1

ORIGINAL SCALE SHOWN IS ONE INCH EQUALS 200 FEET FOR WORKS ON ENLARGED PLANS.
 SHEET: **G2** OF 3

FLOOD CAPTURE RECHARGE PROJECT
 CORCORAN IRRIGATION DISTRICT
 IN KINGS COUNTY NEAR THE CITY OF CORCORAN
 GENERAL

PROJECT INDEX

PRELIMINARY
 NOT FOR CONSTRUCTION
 12/2/2020

FOR REVIEW ONLY

DATE: 12/2/2020

REVISION: 1

BY: [Signature]

DATE: 12/2/2020

43

NILES AVE.

STAIRS

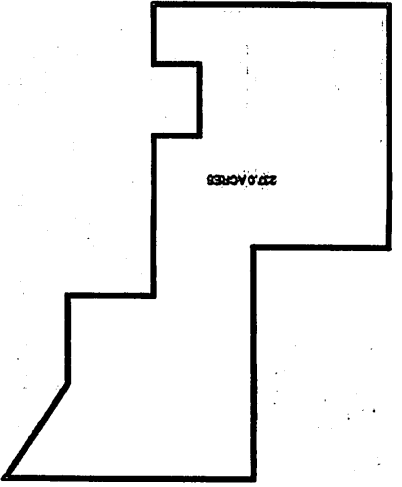

NEVADA AVE

4TH AVE

137



NOTES

1. RECHARGE BASIN AREA AS SHOWN & 20.0 AC.

2. CALL BEFORE YOU DIG.

3. REFER TO SHEET 1818 FOR POWER LINES.

4. REFER TO SHEET 1818 FOR WATER MAINS.

5. REFER TO SHEET 1818 FOR ERECTION OF STRUCTURE.

6. REFER TO SHEET 1818 FOR ERECTION OF WALLS.

7. REFER TO SHEET 1818 FOR ERECTION OF ROOF.

8. REFER TO SHEET 1818 FOR ERECTION OF FLOOR.

9. REFER TO SHEET 1818 FOR ERECTION OF CEILING.

10. REFER TO SHEET 1818 FOR ERECTION OF INTERIORS.

11. REFER TO SHEET 1818 FOR ERECTION OF EXTERIORS.

12. REFER TO SHEET 1818 FOR ERECTION OF LANDSCAPE.

13. REFER TO SHEET 1818 FOR ERECTION OF UTILITIES.

14. REFER TO SHEET 1818 FOR ERECTION OF FINISHES.

15. REFER TO SHEET 1818 FOR ERECTION OF FURNITURE.

16. REFER TO SHEET 1818 FOR ERECTION OF EQUIPMENT.

17. REFER TO SHEET 1818 FOR ERECTION OF SIGNAGE.

18. REFER TO SHEET 1818 FOR ERECTION OF OTHER FEATURES.

19. REFER TO SHEET 1818 FOR ERECTION OF ACCESSORIES.

20. REFER TO SHEET 1818 FOR ERECTION OF FINALS.



<p>PROVOST & PITCHARD</p> <p>REGISTERED PROFESSIONAL ENGINEERS</p> <p>1220 N. 10TH ST. SUITE 100</p> <p>SPRING VALLEY, NV 89717</p> <p>TEL: 702-333-1111</p> <p>FAX: 702-333-1112</p>	<p>FLOOD CAPTURE RECHARGE PROJECT</p> <p>CORPORATE IRRIGATION DISTRICT</p> <p>IN HUMBoldt COUNTY NEAR THE CITY OF CORPORA</p> <p>CNV</p> <p>RECHARGE BASIN DETAIL</p>	<p>FOR REVIEW ONLY</p>	<p>PRELIMINARY</p> <p>NOT FOR CONSTRUCTION</p> <p>1/22/2020</p>	<p>DATE: 1/22/2020</p> <p>BY: [Signature]</p> <p>SCALE: AS SHOWN</p>
--	---	-------------------------------	---	--



Know what's below. Call before you dig.

WARNING



NOTES

1. SEGMENT 1
CUT (APPROX) = 205 CUYD³
TOTAL (APPROX) = 84,774 CUYD
2. EXISTING MEASUREMENTS AT SEGMENT 2 & 3 TRD
3. LEVEL DIMENSIONS AND ELEVATIONS TO BE FIELD VERIFIED

S1

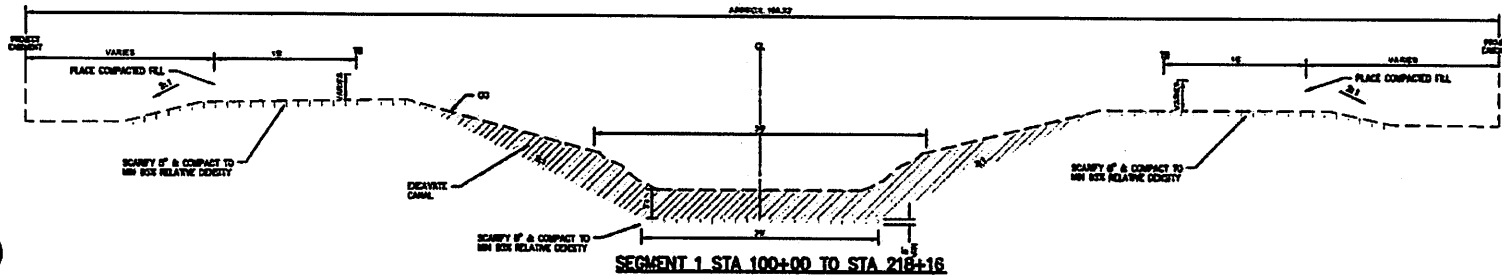

SEGMENT 1 STA 100+00 TO STA 218+16

S2

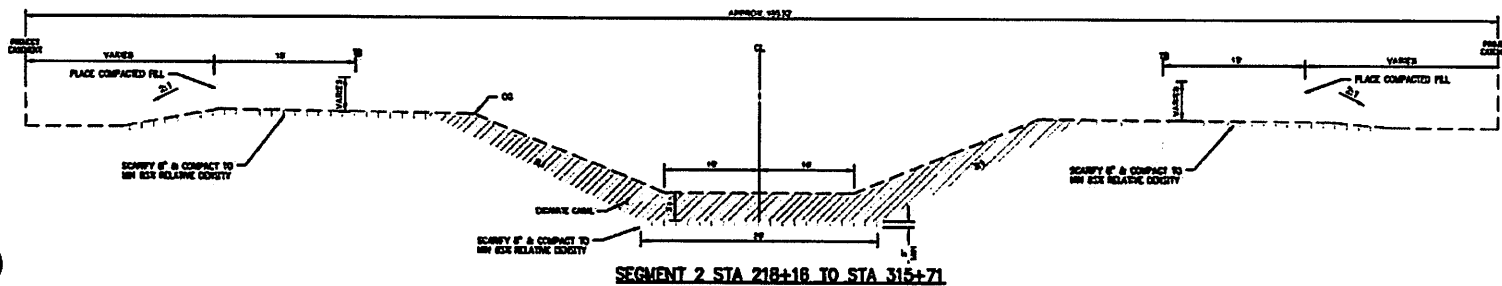

SEGMENT 2 STA 218+16 TO STA 315+71

S3

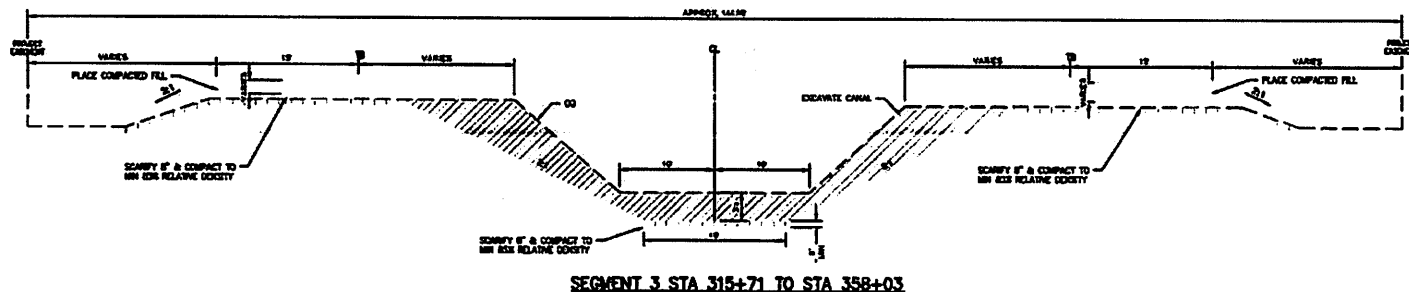

SEGMENT 3 STA 315+71 TO STA 358+03

PROVOST & PRITCHARD ENGINEERS ARCHITECTS
 1000 N. GARDNER ST. SUITE 100
 OMAHA, NE 68102
 PHONE: 402.466.1111
 FAX: 402.466.1112
 WWW: WWW.PPENGINEERS.COM

PRELIMINARY
 NOT FOR CONSTRUCTION
 12/22/2020

FOR REVIEW ONLY

FLOOD CAPTURE RECHARGE PROJECT
 COSBOROAN RECREATION DISTRICT
 IN: KINGS COUNTY NEAR THE CITY OF COSBOROAN
 DETAILS

TYPICAL CANAL SECTIONS

PROVOST & PRITCHARD
 ENGINEERS ARCHITECTS
 1000 N. GARDNER ST. SUITE 100
 OMAHA, NE 68102
 PHONE: 402.466.1111
 FAX: 402.466.1112
 WWW: WWW.PPENGINEERS.COM

DESIGNED BY: G. HORN
 CHECKED BY: AS
 DATE: 01/11/22
 PROJECT NO: 22000
 SHEET NO: 000000
 SHEET: 01

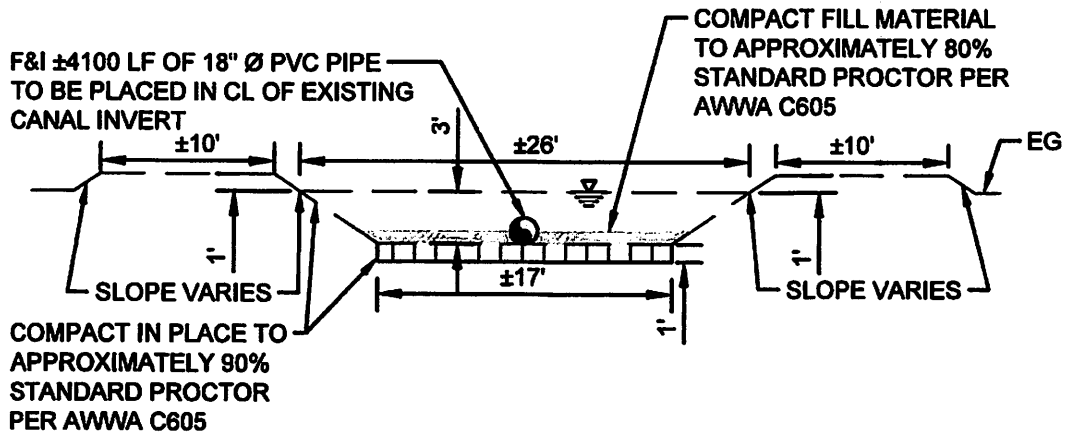

NOT TO SCALE

18" TYPICAL-INSTALLATION CROSS SECTION

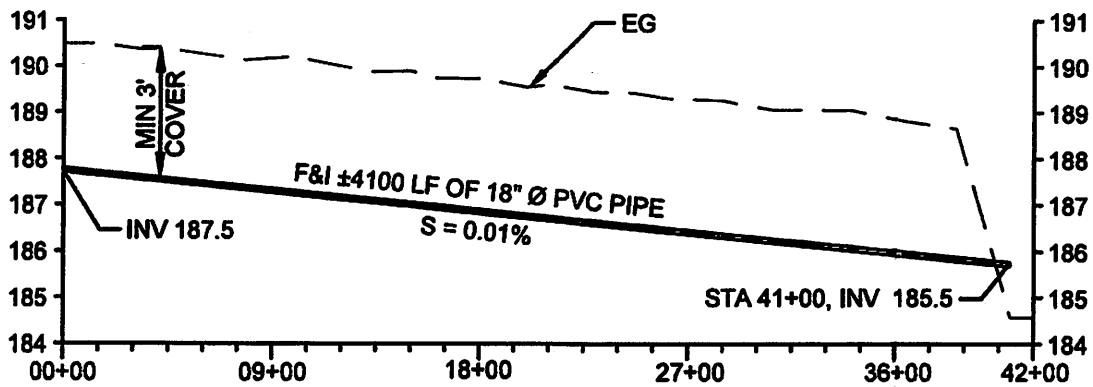

NOT TO SCALE

18" Ø PIPELINE PROFILE

20220211 11:51 AM C:\Users\jpritchard\OneDrive\Documents\20220211\20220211.dwg - 11:51 AM - 11:51 AM



PIPELINE CONVEYANCE CONVERTING
 WIDE CANALS TO PIPELINES
 CORCORAN IRRIGATION DISTRICT
 IN KINGS COUNTY NEAR THE CITY OF CORCORAN

DESIGN ENGINEER:
 CALVIN MONREAL
 DATE: 01/28/2022
 JOB NO: 22001

DETAILS

2 OF 2

**STAFF REPORT
ITEM #: 7-A****MEMO****TO: Corcoran City Council****FROM: Greg Gatzka, City Manager****DATE: February 3, 2022****MEETING DATE: February 8, 2022****SUBJECT: Letter of Support for Tulare Lake Subbasin Groundwater Projects****Summary:**

Corcoran Irrigation District has requested a letter of support from the City of Corcoran for local Tulare Lake Subbasin Groundwater Recharge and Sustainability Projects.

Recommendation:

Consider retroactively authorizing the City Manager to send a letter of support for local groundwater enhancement projects.

Budget impact:

None with this action.

Background:

On January 24, 2022, the Corcoran Irrigation District (CID) sent a letter requesting a letter of support for local groundwater sustainability projects within the Tulare Lake Subbasin. CID is seeking grant funding for two projects. The first project proposes to deepen an existing basin located south of Nevada Avenue and east of 5th Avenue to increase storage and recharge capacity. The second project is the replacement of existing open canals with enclosed pipelines located northeast of Nevada Ave and State Highway 43 to enhance water delivery efficiency.

The deadline for letters of support was January 28, 2022, and did not allow for enough time to bring before the City Council. The City Manager prepared and submitted the attached letter on behalf of the city as these projects are considered to enhance local groundwater management efforts and use of State funding for construction. The City Manager is requesting the City Council retroactively authorize submittal of the attached letter of support.

Attachments:

City Manager Letter of Support.
Corcoran Irrigation District Letter

**STAFF REPORT
ITEM #: 7-B**

MEMO

TO: Corcoran City Council

FROM: Greg Gatzka, City Manager

DATE: February 3, 2022

MEETING DATE: February 8, 2022

SUBJECT: SB 1383 Local Assistance Grant Application

Summary:

California Department of Resources Recycling and Recovery (CalRecycle) is making available a non-competitive grant of \$27,877 to the City of Corcoran for implementation of SB 1383 for mandated organic waste recycling and food recovery.

Recommendation:

Consider approving Resolution No. 3117 to authorize the City Manager to apply for CalRecycle grants for the next 5 years.

Budget impact:

None with this action. If awarded, the city will receive \$27,877 to support SB 1383 implementation efforts that include materials purchase, educational marketing, and staff time.

Background:

On January 4, 2022, the City of Corcoran was notified by CalRecycle that SB 1383 Local Assistance Grant Program funds are available to the City. This grant is non-competitive, and Corcoran is identified as eligible for \$27,877. Grant funds must be used for SB 1383 implementation efforts related to organic waste recycling and edible food recovery. As a new mandated activity, these funds will assist that City in some SB 1383 implementation efforts.

The deadline for submittal was February 1, 2022, by noon. The City Manager in coordination with our Public Works Department and solid waste hauler, prepared and submitted the grant application on time. An approved Council Resolution authorizing the City Manager to apply for the grant is now needed to finalize the application and be submitted by March 1, 2022.

Attachments:

Corcoran City Council Resolution No. 3117
Grant Application Budget Summary

RESOLUTION NO. 3117

**A RESOLUTION OF THE CITY COUNCIL OF THE CITY OF
CORCORAN, CALIFORNIA, AUTHORIZING THE SUBMITTAL OF
APPLICATIONS FOR ALL CALRECYCLE GRANTS FOR WHICH CITY
OF CORCORAN IS ELIGIBLE**

WHEREAS, Public Resources Code sections 48000 et seq. authorize the Department of Resources Recycling and Recovery (CalRecycle) to administer various grant programs (grants) in furtherance of the State of California's (state) efforts to reduce, recycle and reuse solid waste generated in the state thereby preserving landfill capacity and protecting public health and safety and the environment; and

WHEREAS, in furtherance of this authority CalRecycle is required to establish procedures governing the application, awarding, and management of the grants; and

WHEREAS, CalRecycle grant application procedures require, among other things, an applicant's governing body to declare by resolution certain authorizations related to the administration of CalRecycle grants; and

NOW, THEREFORE, BE IT RESOLVED that the Corcoran City Council authorizes the submittal of application(s) to CalRecycle for all grants for which City of Corcoran is eligible; and

BE IT FURTHER RESOLVED that the Corcoran City Manager is hereby authorized and empowered to execute in the name of the City of Corcoran all grant documents, including but not limited to, applications, agreements, amendments and requests for payment, necessary to secure grant funds and implement the approved grant project; and

BE IT FURTHER RESOLVED that these authorizations are effective for five (5) years from the date of adoption of this resolution.

PASSED AND ADOPTED at a meeting of the City Council of the City of Corcoran duly called and held on the 8th day of February 2022, by the following vote of the members thereof:

AYES:

NOES:

ABSENT:

APPROVED: _____
Patricia Nolen, Mayor

ATTEST: _____
Marlene Spain, City Clerk

CLERKS CERTIFICATE

City of Corcoran }
County of Kings } ss.
State of California }

I, Marlene Spain, hereby certify that the foregoing is a full, true and correct copy of a resolution passed and adopted by the City Council of the City of Corcoran at a regular meeting held on the 8th day of February 2022 by the vote as set forth therein.

DATED: February 8, 2021

ATTEST:

Marlene Spain
City Clerk

[seal]



GMSWeb Budget Summary

Lead Participant: City of Corcoran

Cycle Name: SB 1383 Local Assistance Grant Program

Cycle Code: OWR1

Fiscal Year: 2021-22

Grant Number:

Total Budget Amount: \$27,877.00

Amount Awarded: \$0.00

Education

Budget Amount: \$2,500.00

Budget Detail: City Administration staff time for direct outreach with Tier 1 Food sales businesses in conjunction with distribution of 3-bin containers, and instruction on organic waste recycling and food recovery.

Budget Updates:

Indirect Costs

Budget Amount: \$2,000.00

Budget Detail: City Staff associated cost support for SB 1383 Grant implementation activities. Include City Administration staff record keeping and reports, Finance accounting, and other department or contractor staff time in carrying out grant funded procurement or material activities.

Budget Updates:

Marketing/Promotion/Outreach

Budget Amount: \$3,000.00

Budget Detail: Purchase of SB 1383 educational signage for local businesses. Marketing signage to promote enhanced purchase of procurement targets. Educational outreach materials for distribution to City residents through either direct City mailers or contracted waste hauler distribution.

Budget Updates:

Materials

Budget Amount: \$20,377.00

Budget Detail: Purchase of Kitchen Collection food scrap pails for distribution to residents estimated at \$9,000. Purchase of mixed 3-bin recyclables-organics-trash collectors for local businesses and large lunchrooms estimated at \$6,800. Purchase of procurement required targets including compost/mulch for City landscaping, and recycled paper products for City office use.

Budget Updates:

City of

CORCORAN

A MUNICIPAL CORPORATION

FOUNDED 1914

MATTERS FOR MAYOR AND COUNCIL

ITEM #: 8

MEMORANDUM

MEETING DATE: February 8, 2022
TO: Corcoran City Council
FROM: Greg Gatzka, City Manager
SUBJECT: Matters for Mayor and Council

8-A. Upcoming Events/Meetings

- February 21, 2011 (Monday) City Offices Closed in Observance of President's Day
- February 22, 2022 (Tuesday) City Council Meeting – 5:30 PM
- March 8, 2022 (Tuesday) City Council Meeting – 5:30 PM
- March 22, 2022 (Tuesday) City Council Meeting – 5:30 PM

8-B. City Manager's Report

8-C. Council Comments/Staff Referral Items – *This is the time for council members to comment on matters of interest.*

8-D. Committee Reports

1. Kings Waste and Recycling Agency (KWRA)
2. Kings County Association of Governments (KCAG)
3. Kings Community Action Organization

City Offices



**COUNCIL REQUESTS OR REFERRAL ITEMS
PENDING FURTHER ACTION or RESOLUTION BY STAFF**

DATE Sent to Council/ Request made	REQUEST	STATUS	DEPARTMENT RESPONSIBLE Dept/Division
01/25/22	Corcoran Cemetery District concerns. Council directed City Manager to make contact with District representatives and lend support.	In progress	City Manager
07/21/21	Homelessness Concerns. Council directed staff to explore and evaluate avenues to address homeless issues.	In progress	City Manager
07/21/21	Vacant and blighted commercial properties. Council directed staff to begin preparing an abatement ordinance.	In progress	Community Development
06/13/20	Council directed Staff to begin preparing a public nuisance ordinance.	In progress	Community Development/Police Department
03/12/19	Council requested that Staff prepare ordinance specifically prohibiting smoking in public parks. It was recommended that the City also consider an ordinance prohibiting dogs in public parks.	In progress	Community Development